

R15KPxxA SERIES

V_R : 17 - 240 Volts

P_{PK} : 15,000 Watts

FEATURES :

- * Glass passivated junction chip
- * Excellent Clamping Capability
- * Fast Response Time
- * Low Zener Impedance
- * Low Leakage Current
- * Fast Response Time : typically less than 1.0ps from 0 volt to BV, Bidirectional less than 10ns
- * High temperature soldering guaranteed : 265°C/10 second, 0.375", (9.5mm) lead length.
- * **Pb / RoHS Free**

MECHANICAL DATA

- * Case : Reliable low cost construction utilizing molded plastic technique
- * Epoxy : UL94V-0 rate flame retardant
- * Terminals : Plated leads solderable per MIL-STD-202, Method 208 guaranteed
- * Polarity : Polarity symbols marked on case
- * Mounting position : Any
- * Weight : 1.29 grams

MAXIMUM RATINGS (Ta = 25°C)

Rating	Symbol	Value	Unit
Peak Pulse Power Dissipation (10X1000μs, see Fig.1)	P _{PK}	15,000	W
Steady State Power Dissipation	P _D	7.0	W
Operating and Storage Temperature Range	T _J , T _{STG}	- 55 to + 175	°C

TRANSIENT VOLTAGE SUPPRESSORS

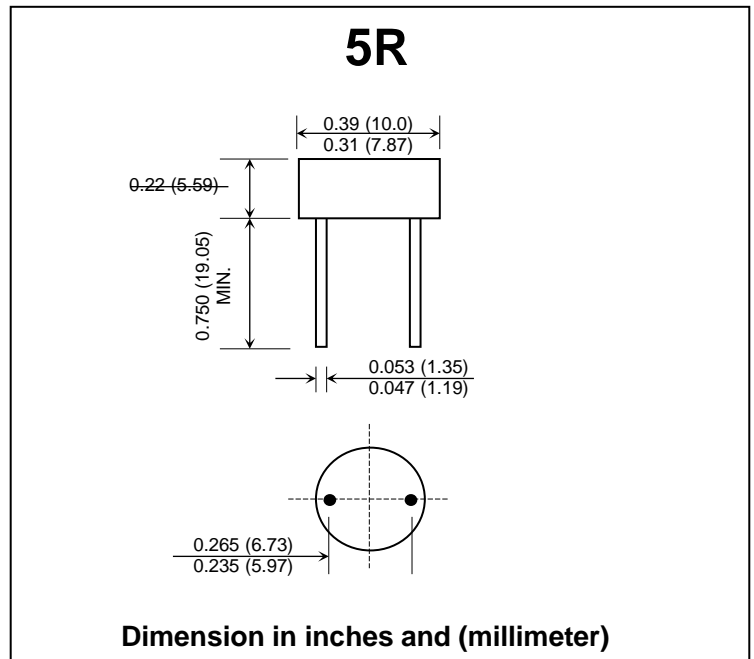

ELECTRICAL CHARACTERISTICS

Rating at 25 °C ambient temperature unless otherwise specified

Type No.	Reverse Stand Off Voltage	Breakdown Voltage @ I _T			Maximum Reverse Leakage @ V _R	Maximum Clamping Voltage @ I _{PP}	Maximum Peak Pulse Current	Max. Voltage Temperature Variation of V _{BR} (mV/°C)
		V _{BR} (V)		I _T				
	V _{WM} (V)	Min.	Max.	(mA)	I _R (μA)	V _C (V)	I _{PP} (A)	
R15KP17	17	18.9	23.1	50	5,000	32.2	464	19
R15KP17A	17	18.9	20.9	50	5,000	29.3	512	17
R15KP18	18	20.0	24.4	50	5,000	34.2	439	20
R15KP18A	18	20.0	22.1	50	5,000	30.9	485	18
R15KP20	20	22.2	27.1	20	1,500	37.9	396	24
R15KP20A	20	22.2	24.5	20	1,500	34.3	437	21
R15KP22	22	24.4	29.8	10	500	41.1	365	27
R15KP22A	22	24.4	26.9	10	500	37.1	404	24
R15KP24	24	26.7	32.6	5.0	150	45.0	333	30
R15KP24A	24	26.7	29.5	5.0	150	40.7	369	27
R15KP26	26	28.9	35.3	5.0	50	48.7	308	32
R15KP26A	26	28.9	31.9	5.0	50	44.0	341	29
R15KP28	28	31.1	38.0	5.0	25	52.4	286	35
R15KP28A	28	31.1	34.4	5.0	25	47.5	316	31
R15KP30	30	33.3	40.7	5.0	15	56.2	267	37
R15KP30A	30	33.3	36.8	5.0	15	50.7	296	33
R15KP33	33	36.7	44.9	5.0	10	60.6	248	42
R15KP33A	33	36.7	40.6	5.0	10	54.8	274	38
R15KP36	36	40.0	48.9	5.0	10	66.0	227	46
R15KP36A	36	40.0	44.2	5.0	10	59.7	251	41
R15KP40	40	44.4	54.3	5.0	10	72.8	206	51
R15KP40A	40	44.4	49.1	5.0	10	65.8	228	46
R15KP43	43	47.8	58.4	5.0	10	77.1	195	55
R15KP43A	43	47.8	52.8	5.0	10	69.7	215	50
R15KP45	45	50.0	61.1	5.0	10	80.7	186	57
R15KP45A	45	50.0	55.3	5.0	10	73.0	205	52
R15KP48	48	53.3	65.1	5.0	10	85.9	175	62
R15KP48A	48	53.3	58.9	5.0	10	77.7	193	56
R15KP51	51	56.7	69.3	5.0	10	91.5	164	66
R15KP51A	51	56.7	62.7	5.0	10	82.5	181	60
R15KP54	54	60.0	73.3	5.0	10	96.8	155	70
R15KP54A	54	60.0	66.3	5.0	10	87.5	171	63
R15KP58	58	64.4	78.7	5.0	10	104	144	76
R15KP58A	58	64.4	71.2	5.0	10	94	160	68
R15KP60	60	66.7	81.5	5.0	10	107	140	78
R15KP60A	60	66.7	73.7	5.0	10	97.3	154	70
R15KP64	64	71.1	86.9	5.0	10	115	130	84
R15KP64A	64	71.1	78.6	5.0	10	104	144	76
R15KP70	70	77.8	95.1	5.0	10	126	119	92
R15KP70A	70	77.8	86.0	5.0	10	114	132	83
R15KP75	75	83.3	102	5.0	10	135	111	100
R15KP75A	75	83.3	92.1	5.0	10	122	123	89
R15KP78	78	86.7	106	5.0	10	140	107	104
R15KP78A	78	86.7	95.8	5.0	10	126	119	93

ELECTRICAL CHARACTERISTICS

Rating at 25 °C ambient temperature unless otherwise specified

Type No.	Reverse Stand Off Voltage	Breakdown Voltage @ I _T			Maximum Reverse Leakage @ V _R	Maximum Clamping Voltage @ I _{PP}	Maximum Peak Pulse Current	Max. Voltage Temperature Variation of V _{BR} (mV/°C)
	V _{WM}	V _{BR} (V)		I _T	I _R	V _C	I _{PP}	
	(V)	Min.	Max.	(mA)	(μA)	(V)	(A)	
R15KP85	85	94.4	115	5.0	10	152	99	113
R15KP85A	85	94.4	104	5.0	10	137	109	102
R15KP90	90	100	122	5.0	10	160	94	120
R15KP90A	90	100	111	5.0	10	146	103	110
R15KP100	100	111	136	5.0	10	179	84	134
R15KP100A	100	111	123	5.0	10	162	93	123
R15KP110	110	122	149	5.0	10	196	77	147
R15KP110A	110	122	135	5.0	10	178	84	133
R15KP120	120	133	163	5.0	10	214	70	161
R15KP120A	120	133	147	5.0	10	193	78	146
R15KP130	130	144	176	5.0	10	231	65	174
R15KP130A	130	144	159	5.0	10	209	72	158
R15KP150	150	167	204	5.0	10	268	56	202
R15KP150A	150	167	185	5.0	10	243	62	184
R15KP160	160	178	218	5.0	10	287	52	216
R15KP160A	160	178	197	5.0	10	259	58	196
R15KP170	170	189	231	5.0	10	304	49	229
R15KP170A	170	189	209	5.0	10	275	55	208
R15KP180	180	200	244	5.0	10	321	47	242
R15KP180A	180	200	221	5.0	10	287	52	220
R15KP200	200	222	271	5.0	10	356	42	296
R15KP200A	200	222	245	5.0	10	325	46	274
R15KP220	220	245	299	5.0	10	393	38	297
R15KP220A	220	245	271	5.0	10	347	43	273
R15KP240	240	267	326	5.0	10	428	35	324
R15KP240A	240	267	295	5.0	10	387	39	300

Note: (1) Suffix " A " denotes 5% tolerance device , no suffix denotes a 10% tolerance device.

RATING AND CHARACTERISTIC CURVES (R15KPxxA SERIES)

Fig. 1 - Pulse Wave Form

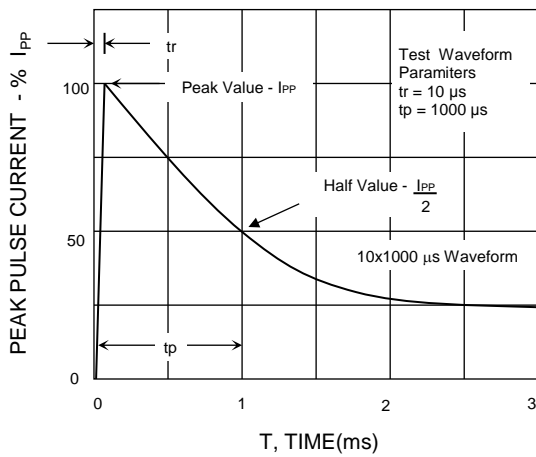

Fig. 2 - Peak Pulse Power vs. Pulse Time

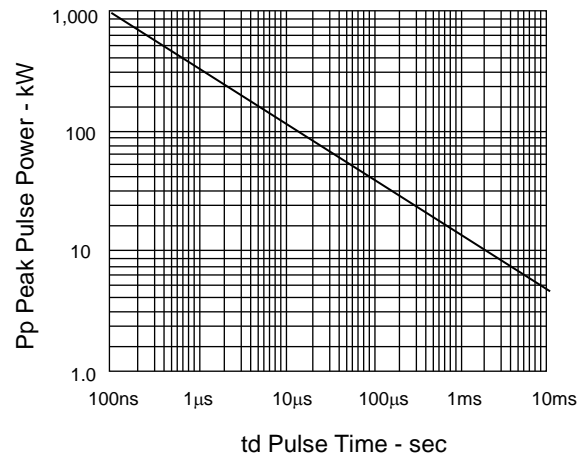

Fig. 3 - Typical Capacitance vs. Breakdown Voltage

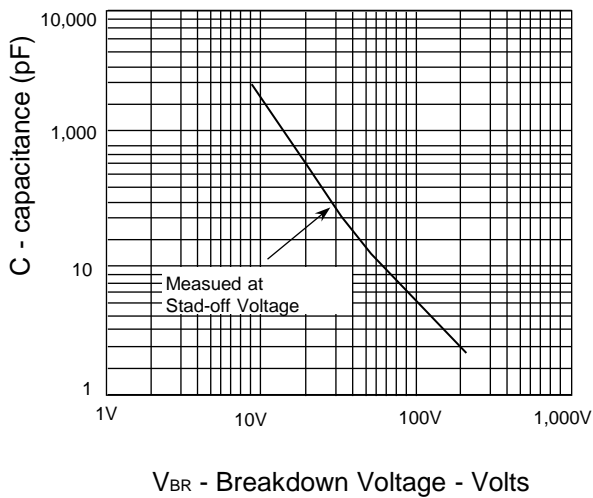

Fig. 4 - Derating Curve

